

## Tesla Coil: History and Didactic Construction

Lucas Brugnaro Badur (IC), Gilmar Barreto (PQ), Romis R. de F. Attux (PQ), Leandro T. Manera (PQ)

### Abstract

Nikola Tesla, with his unconventional interpretation of nature, brought countless innovations. The analysis of his vision brings us a greater comprehension of subjects previously established as having one purpose. By reproducing one of his experiments, the Tesla Coil, we can evince the simplicity and genius in the proposed interpretations.

Key words: Nikola Tesla, Transformers, Coil

### Introduction

Nikola Tesla, inventor, engineer, and visionary, spent his life creating and idealizing projects associated with electricity.

With more than 270 patents and many inventions not patented, his discoveries were invaluable to the life of the man of today.

An invention that carries his name – the Tesla coil – hasn't many commercial applications, but proves how an inventive mind can figure out other purposes to technologies we already master.

The work we developed explores the inventor's life, recreating a few of his experiments to study and ultimately better understand his line of thought.

### Results and Discussion

The Tesla coil was built with attention to the inventor's original schematics, but in a reduced scale. The concept of reuse was also used, employing simple materials for the concept and creation of the coil.

A Tesla coil is a simple circuit, with a transformer that generates high-voltage, low-current, high-frequency electricity. Its circuits can be used in a plethora of applications, but nowadays they are used almost exclusively in demonstrations.

The coil works by elevating the voltage of a source with the first transformer, followed by an increase of frequency due to the presence of a spark gap and a high-voltage capacitor. The second transformer transfers the energy, while also elevating the voltage further, to the output terminal, producing voltaic arcs.

The coil produces an estimated voltage of approximately 8000 Volts, in high frequency and low current. This value is estimated by observing the distance between the toroid at the top of the coil and the ground terminal.

During a class given at the State University of Campinas, students of the Principles of Energy Conversion Lab could see the Tesla coil operating. This unexpected use of a simple transformer circuit helped instigate students to reflect about the conventional use of technologies we have today.

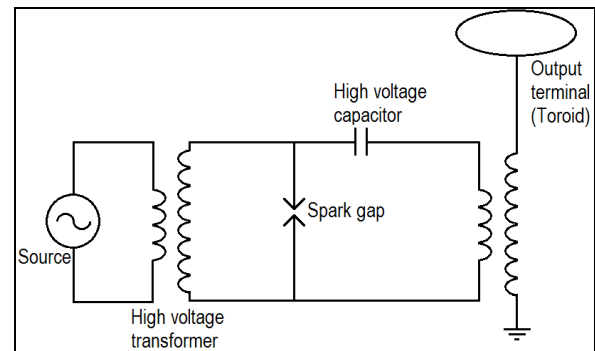

Figure 1. Schematic of a Tesla Coil



Figure 2. The built Tesla Coil (25cm tall)

### Conclusions

One of the main objectives of the work we have been doing is to rouse an interest of students in the historical aspects of Electrical Engineering, and thus motivate them to seek out their own brand of knowledge, which goes beyond conventional classes, theoretical or practical. We believe that, by recreating some of the genius experiments proposed by Tesla, there can be an ampler comprehension of what is formally learned, and hence an enrichment of what is taught in class.

<sup>1</sup> CHENEY, M. *Tesla: A Man out of Time*. Touchstone, 2001. 400 p.

<sup>2</sup> TESLA, N. *Experiments with Alternate Currents of High Potential and High Frequency*. CreateSpace Independent Publishing Platform, 2012. 88 p.

<sup>3</sup> TESLA, N. *My Inventions: The Autobiography of Nikola Tesla*. Ancient Wisdom Publications, 2011. 70 p.

<sup>4</sup> The Complete Nikola Tesla U.S. Patent Collection. Available in <[http://web.mit.edu/most/Public/Tesla1/alpha\\_tesla.html](http://web.mit.edu/most/Public/Tesla1/alpha_tesla.html)>. Accessed in 10 mar 2015.